

---

**Please include the following attribution when using any part of this presentation information in a report, presentation, article, etc.**

***Presented by Robert Bedick, National Energy Technology Center, at the Coal Utilization Technologies Workshop on September 22, 2004 at the National Research Center for Coal & Energy, Morgantown, WV. This meeting was part of the Energy Roadmap Workshop Series commissioned by West Virginia Governor Bob Wise.***



# Advancements in Coal-Fired Power Generation Technologies



*WV Energy Roadmap  
Workshop Series on Coal  
Utilization Technologies*

*Robert C. Bedick,  
FutureGen Project Director  
September 22, 2004*

**National Energy Technology Laboratory**



---

**Please include the following attribution when using any part of this presentation information in a report, presentation, article, etc.**

***Presented by Robert Bedick, National Energy Technology Laboratory, at the Coal Utilization Technologies Workshop on September 22, 2004 at the National Research Center for Coal & Energy, Morgantown, WV. This meeting was part of the Energy Roadmap Workshop Series commissioned by West Virginia Governor Bob Wise.***



# Coal and Power Systems At DOE

## *R&D Program*

- Materials for UltraSuper Critical Steam Cycles
- Hybrid Combustion-Gasification Chemical Looping
- 2-Reactor Catalytic Unmixed Combustion
- System Analysis/Technology Integration
- Boeing Company – Gasification Research

## *Demonstration Program*

- Hybrid Gasification Combined Cycle

## *FutureGen*

- Integrated Sequestration, Hydrogen, and Power Showcase Facility



## New Plant Performance Targets *Based on Roadmapping With Industry*

	<i>Ref. Plant</i>	<i>2010</i>	<i>2020*<sup>1</sup></i>
<b>SO<sub>2</sub> Removal</b>	<b>98%</b>	<b>99%</b>	<b>&gt;99%</b>
<b>NO<sub>x</sub>, lb/10<sup>6</sup> Btu</b>	<b>0.15</b>	<b>0.05</b>	<b>&lt;0.01</b>
<b>Particulate, lb/10<sup>6</sup> Btu</b>	<b>0.01</b>	<b>0.005</b>	<b>0.002</b>
<b>Mercury Removal</b>	<b>–</b>	<b>90%</b>	<b>95%</b>
<b>Byproduct Use</b>	<b>30%</b>	<b>50%</b>	<b>~100%</b>
<b>Efficiency, HHV</b>	<b>40%</b>	<b>45–50%</b>	<b>50–60%</b>
<b>Availability</b>	<b>&gt;80%</b>	<b>&gt;85%</b>	<b>≥90%</b>
<b>Capital Cost, \$/kW</b>	<b>900–1,300</b>	<b>900–1,000</b>	<b>800–900</b>
<b>Cost Electricity, ¢/kWh</b>	<b>3.5</b>	<b>3.1</b>	<b>&lt;3.0</b>
<b>Cost H<sub>2</sub>, \$/MMBtu</b>	<b>6.00*<sup>2</sup></b>	<b>–</b>	<b>4.00</b>



\*<sup>1</sup> Sequestration Ready Plant; \*<sup>2</sup> Produced Using \$3.50 MBtu Natural Gas

Descriptor - include initials, /org#/date

# Materials for UltraSuper Critical Steam Cycles Energy Industries of Ohio

## Goal

- Develop materials technology for 760°C / 35 MPA PC plant.

## Benefits

- High efficiency / low emission PC Plants
- Cost reduction due to fuel saving
- Technology applicable to all power systems
- Retrofit application to existing plants
- Enable domestic manufacturers to compete in world markets

## Candidate Alloys

- Sumitomo: Save 12, Super 304H, and HR6W
- Haynes: Haynes 230
- Krupp VDM: CCA 617
- Special Metals: INCO 740



# Hybrid Combustion-Gasification Chemical Looping

## ALSTOM Power, Inc

### High Temperature Chemical and Thermal Looping Technology

- **Two chemical loops**
  - Calcium sulfide (CaS) / calcium sulfate (CaSO<sub>4</sub>)
  - Lime (CaO) / calcium carbonate (CaCO<sub>3</sub>)
- **One thermal loop**
  - Heat from the exothermic oxidation reactions used to satisfy endothermic reaction energy requirements

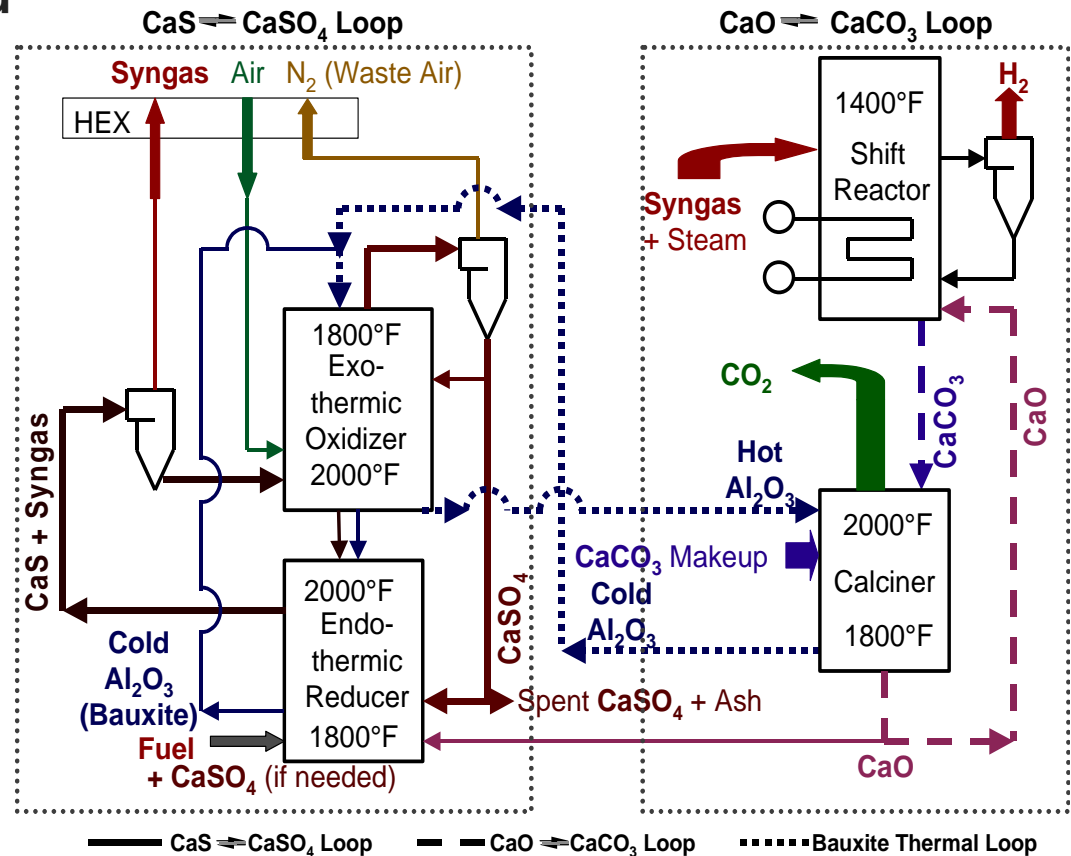

# 2-Reactor Catalytic Unmixed Combustion (UMC) GE Global Research

## 2-Reactor UMC

- Separated CO<sub>2</sub>
- Vitiated air to combined cycle

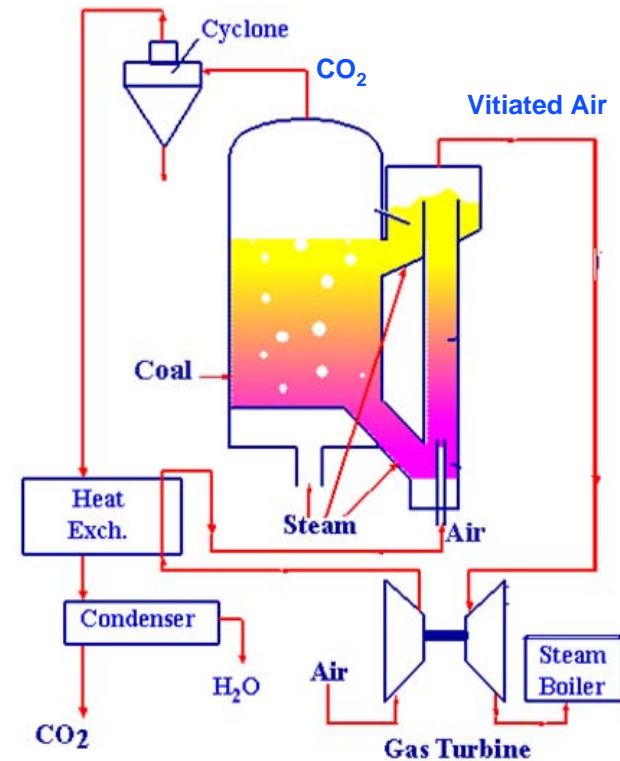

# Goal: Utilization of Coal for Power Production to be as Clean or Cleaner than Power from Natural Gas, and as Economic

## Challenges

Optimization of Domestic Coal Use with

- Zero emissions
- High efficiency
- Low cost plants

for production of

- Electric power
- Fuels
- Chemical
- Hydrogen

Reduction of Power Plant Pollutants (NO<sub>x</sub>, SO<sub>x</sub>, Hg, PM)

Reduction of Carbon Dioxide Emissions

Maintain Low Cost of Electricity to the Public through diversified mix of indigenous fuels

## R&D Pathways

### By 2010:

- Advanced Gasification
- E-Gas/Dry Feed
- Warm gas cleaning (all contaminants including Hg.
- Hg capture
- 7FB gas turbines
- ITM oxygen
- 85 % capacity
- 98 % carbon conversion

### By 2020:

All of 2010 improvements  
Plus:

- H Frame gas turbines
- SOFC topping cycle
- 90 % capacity
- Improved component integration.
- Carbon capture & sequestration

## Targets

### By 2010

- Efficiency 45-50% (HHV)
- Capital \$900-1000/kW

### By 2020

- Efficiency 50-60% (HHV)
- Capital \$850/kW
- Targets for Plants without Carbon Capture



# COE Timeline

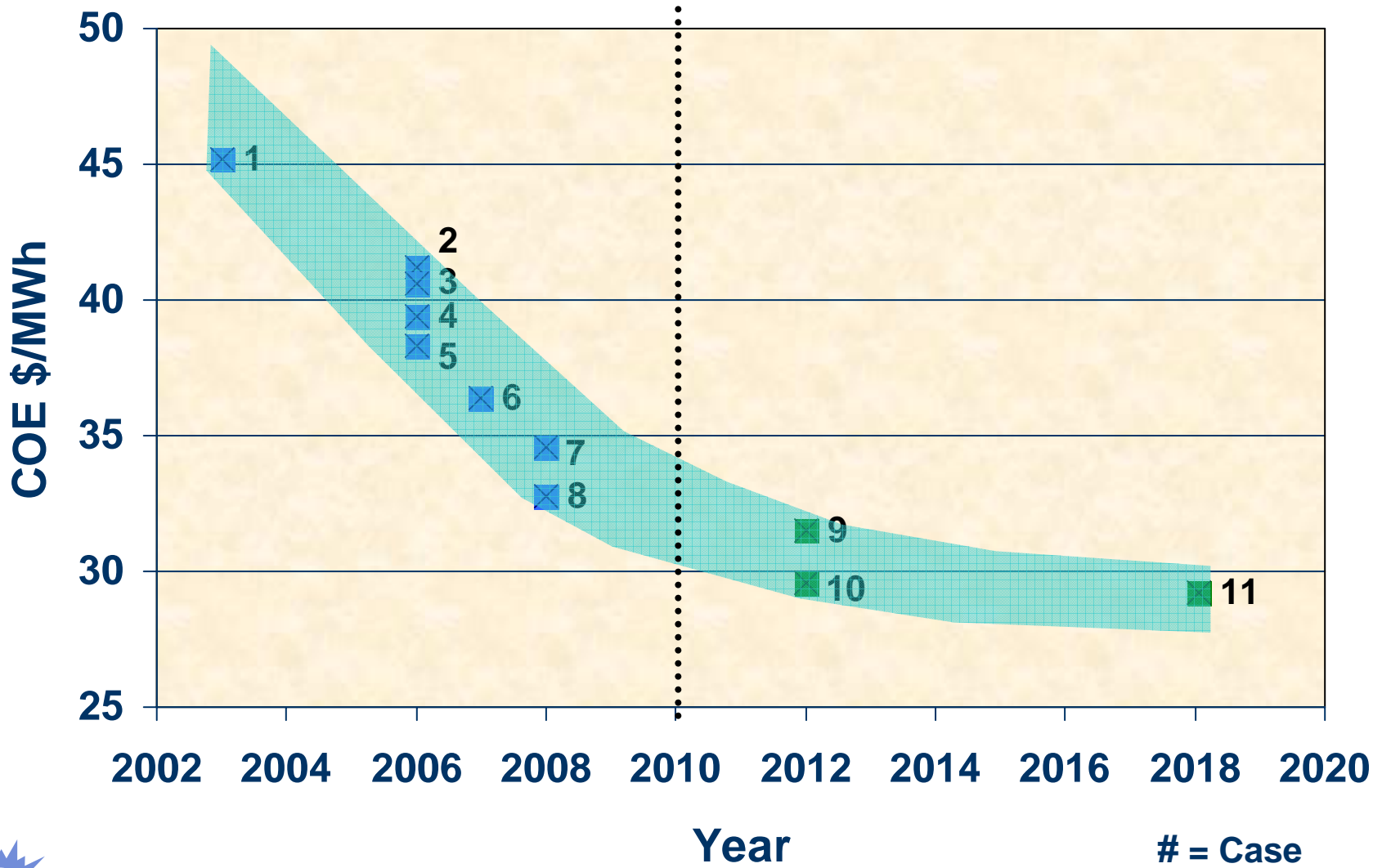

# Boeing Company – Gasification Research

## Project Objectives

- **Demonstrate Long-Life Rapid-Mix Injectors**
  - Extend life with reduced operating temperatures and improve performance with rapid mix design
- **Test Cooled Refractory Liner Coupons**
  - Actively Cooled Ceramic Matrix Composite
- **Perform Conceptual Design and Hardware Definition of a Novel 24 tpd Gasifier**
  - Plug Flow Gasifier
  - Rapid-Mix Injectors
  - Cooled Refractory Liner
  - CO<sub>2</sub> Slurry Feed System



# Boeing Company – Gasification Research

## Benefits:

- **Long-Life Rapid Mix Injectors**
  - Increase Carbon Conversion to Nearly 100%
  - Reduce Gasifier Residence Time from 5 Sec to  $< \frac{1}{2}$  Sec
  - Increase Feed Injector Life from 2-6 Months to ~1 YR
- **Cooled Refractory Liner**
  - Increase Liner Life from 6-18 Months to over 3 Years
  - Increase Gasifier Annual Availability by Over 5%
- **CO<sub>2</sub> Slurry Feed System**
  - Gasify all Ranks of Coal
  - 24% Oxygen Reduction (over Wet Feed, 1-Stage Gasifier)
  - 30% Oxygen Reduction (over Dry Feed, 2-Stage Gasifier)



# Hybrid Gasification Combined Cycle Basin Electric Power Cooperative

- Repowering their Leland Olds Unit 2 to Pioneer the First ever HGCC
- A Type of Gas Turbine Combined Cycle that is Supplied with Fuel Energy by Two Systems
  - Pressurized Gasifier
  - Atmospheric Pressure Circulating Fluidized Bed Boiler

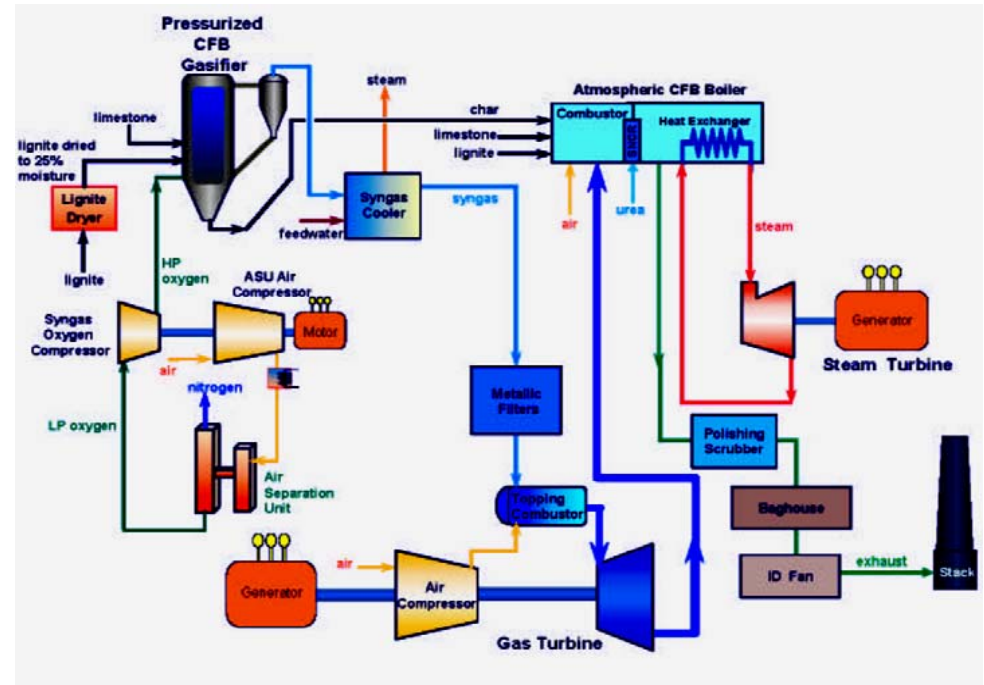

Potentially offers a new way of making electricity focused on low rank and sub-bituminous coals that would be superior for both repowering existing units and new lignite-burning units.



# FutureGen - A “Zero Emissions” Plant

 **FutureGen** will test new technologies to capture CO<sub>2</sub> at the power plant

 **FutureGen** will test large-scale injection into oil fields or into deep geologic formations for permanent storage

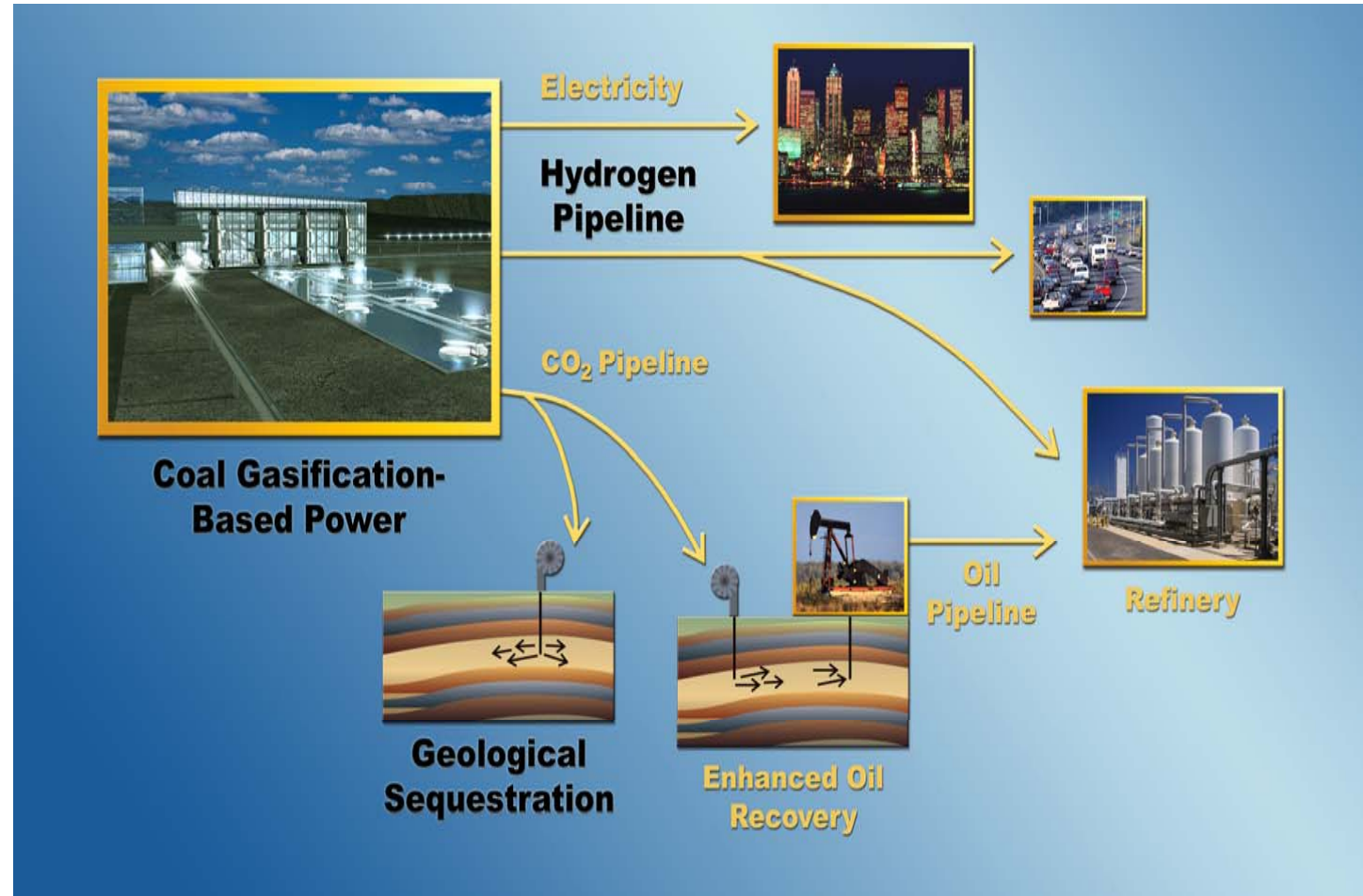

# FutureGen

## RD&D to Meet Technology Challenge

### Traditional Advanced Technology

Cryogenic Separation

Amine Scrubbers

Amine Scrubbers

Gas Stream Clean-Up

Syngas Turbine

Fuel Cell (\$4,000/kW)

EOR based

Existing Gasifier

System Integration

Plant Controls

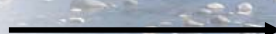
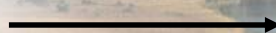
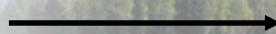

### Research Inventions

O<sub>2</sub> Membranes

Hydrogen Membranes

“Clathrate” CO<sub>2</sub> Separation

“Dirty” Shift Reactor

Hydrogen Turbine

SECA Fuel Cell (\$400/kW design)

Sequestration Technology

(including in-situ CO<sub>2</sub> monitoring)

Advanced Transport Reactor

“First of a Kind” System Integration

“Smart” Dynamic Plant Controls & CO<sub>2</sub> Management Systems



# Visit The Strategic Center for Coal Website

<http://www.netl.doe.gov/coal/>

**NATIONAL ENERGY TECHNOLOGY LABORATORY**  
THE STRATEGIC CENTER FOR COAL

Home | Search | Site Index | Feedback

**NETL**

Overview  
Ref. Shelf  
Coal Primer  
Contacts

## The Strategic Center for Coal

*Developing clean, affordable, and reliable coal-to-energy technologies*

Welcome to NETL's Strategic Center for Coal. Our mission is to create technology pathways for ultra-clean coal-to-energy plants—capable of supporting the continued use of coal now and well into the future so that this country can rely on this secure and plentiful energy resource to provide the affordable electricity (and other useful products) our competitive economy requires. Through sustained public and private sector investments in the science and technology of coal and through partnerships with the nation's energy industry, we hope to bring about evolutionary in the near-term and revolutionary changes in the long term, the way power and fuels are produced from coal.

Advanced Research  
Carbon Sequestration  
CCPI/Clean Coal Demonstrations  
Combustion  
Distributed Generation  
Environmental & Water Resources  
Fuels  
FutureGen  
Gasification  
Turbines

For more information about the national coal research, development and demonstration program sponsored by the Department of Energy's Office of Fossil Energy, see the [Overview](#).

Our site is designed to answer your questions about coal research, development and demonstration. If you're looking for more information, our [Reference Shelf](#) will serve as your key research tool. Please explore our site and [contact us](#) with any questions.

**President's Clean Coal Initiative Attracts "Second Wave" of Technologies**  
DOE has received proposals for projects valued at nearly \$6 billion in the latest phase of the President's Clean Coal Power Initiative, demonstrating industry's willingness to invest in a new generation of clean coal technologies. [Read More!](#)

**Clean Coal Project Aims to Enhance the Value of High Moisture Coals**  
Great River Energy will test their Lignite Fuel Enhancement System in a new project to boost the efficiency of, and reduce emissions from, power plants that burn high moisture lignite coal. [Read More!](#)

<http://www.netl.doe.gov/coal/> (1 of 2)9/16/2004 10:46:27 AM

